

PROJECT QUESTIONNAIRE

ROMOLD PE- cable chamber DN 1000, water tight high model, accessible

Romold GmbH
 Sägewerkstraße 5
 D-83416 Surheim
 Tel: +49-8654-4768-0
 Fax: +49-8654-4768-47
 E-mail: verkauf@romold.de



order request for information

project: _____

chamber no.: _____

model: **o KS 100.63/110 SBL**
 height H=ca.108cm

- ROMOLD - system cover:
 class: PE- lid A15 B125 D400
please indicate
- concrete load distribution ring
 for commercial, water tight cover system
 up to class D400

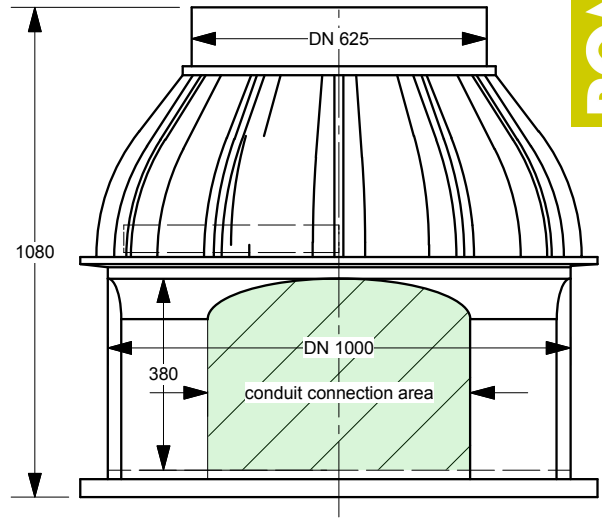

*) for informations regarding max. conduit connection see internet:
www.romold.de -> products -> electrics and telekommunikations
 -> cable chambers model KS/FC

conduit connection*)

side D	number
OD	
OD	
OD	

side A

conduit connection*)

side A	number
OD	
OD	
OD	

side D

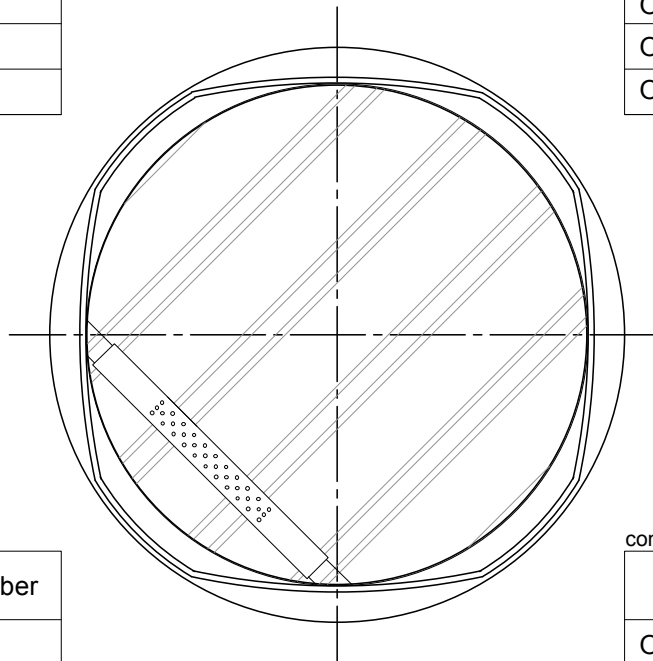

side B

conduit connection*)

side C	number
OD	
OD	
OD	

side C

conduit connection*)

side B	number
OD	
OD	
OD	

company: _____

contact person: _____

tel. / fax: _____

E-mail: _____

stamp

date, signature